

THIS DOCUMENT CONTAINS PROPRIETARY INFORMATION, AND EXCEPT WITH WRITTEN PERMISSION OF CALIFORNIA LINEAR DEVICES, INC., SUCH INFORMATION SHALL NOT BE PUBLISHED OR DISCLOSED TO OTHERS, OR USED FOR ANY PURPOSE, AND THE DOCUMENT SHALL NOT BE DUPLICATED IN WHOLE OR IN PART.

DWG NO. ICD - 40202D SH 1 REV. A

REVISION HISTORY			
REV.	DESCRIPTION	DATE	APPROVED
A	INITIAL RELEASE PER ECO #0109	2/7/03	PH

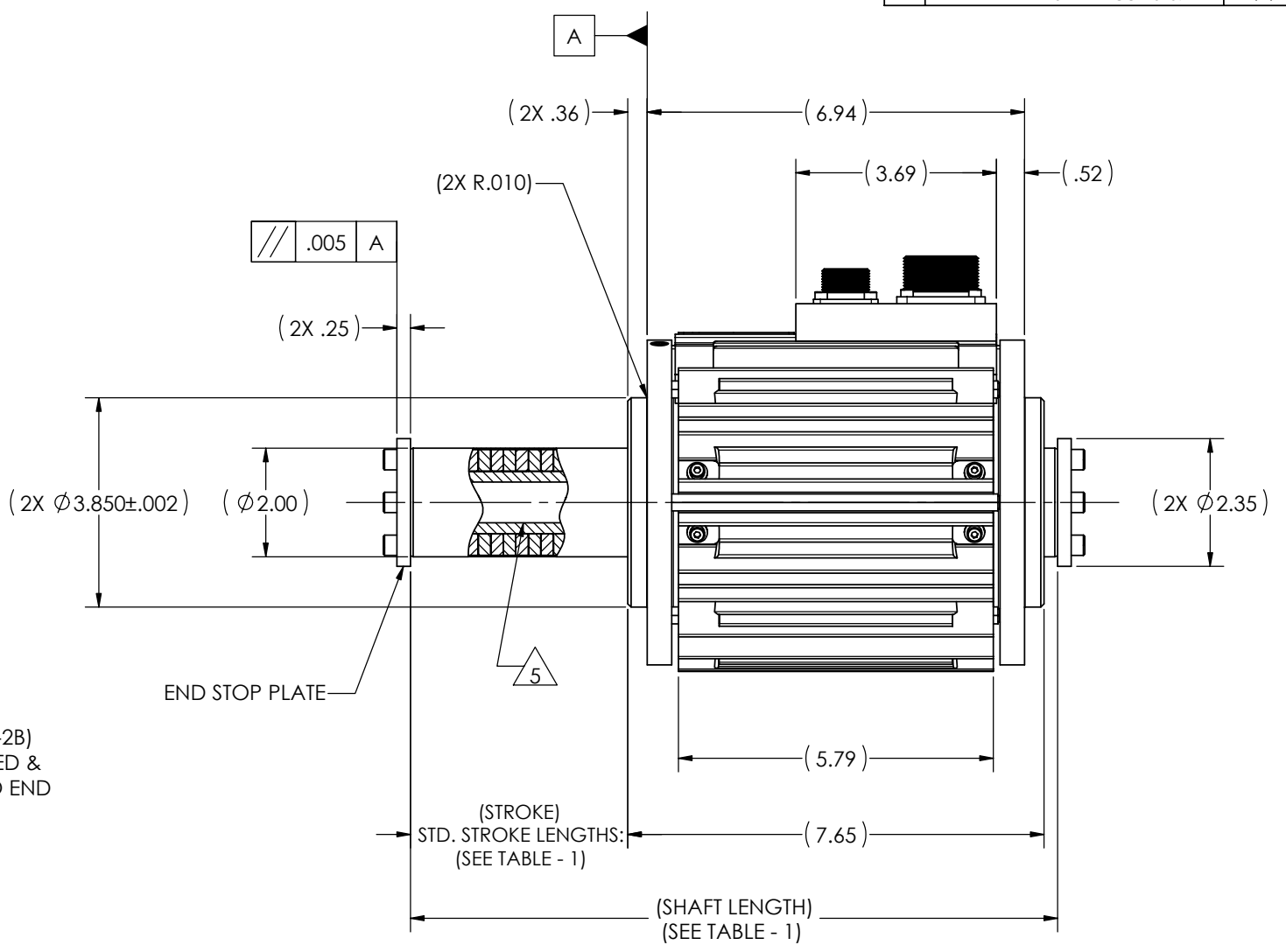
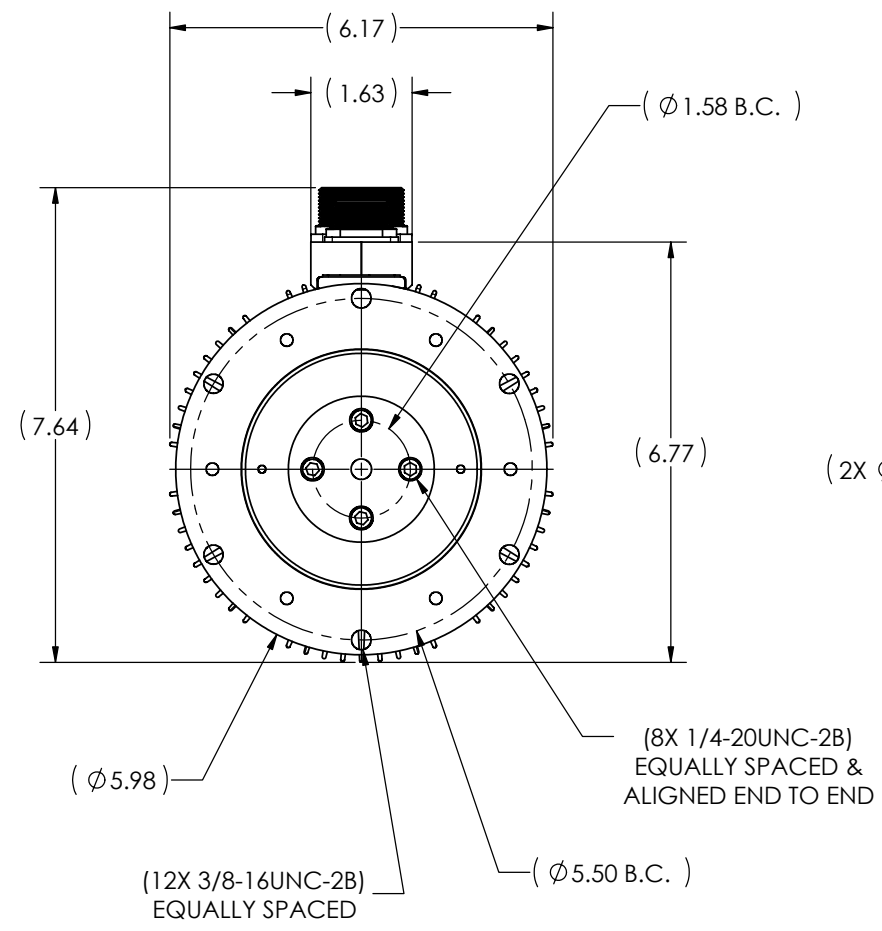

INTERFACE CONTROL DRAWING

5. MOTOR SHAFT CONTAINS A .75 STANDARD TUBING INNER DIAMETER.

- FOR INFORMATION NOT CONTAINED ON THIS DRAWING, REFER TO USERS MANUAL (REF. UM-102).
- MODEL SHOWN: 40202D...-...-CV.
- THE MOTOR BEARINGS ARE NOT INTENDED TO SUPPORT RADIAL LOADS. THIS WILL RESULT IN ACCELERATED BEARING WEAR. PLEASE CONSULT CLD REGARDING YOUR APPLICATION IF RADIAL LOADS ARE EXPECTED.
- CAUTION: DO NOT OPERATE THE MOTOR WITHOUT THE END STOP PLATES OR AN EXTERNAL STOP TO CONTAIN THE SHAFT IN THE STATOR.

NOTES: UNLESS OTHERWISE SPECIFIED

MODEL NO.	STROKE LENGTH IN INCHES (NOMINAL)	POLE PITCH IN INCHES	ESTIMATED MOTOR WEIGHT IN LBS.	ESTIMATED SHAFT WEIGHT IN LBS.	SHAFT LENGTH IN INCHES
40202D02-...-...	2.40	.922	33	8	10.05
40202D04-...-...	4.25		34	9	11.90
40202D06-...-...	6.05		35	10	13.70
40202D08-...-...	8.35		37	12	16.00
40202D10-...-...	10.20		38	13	17.85
40202D12-...-...	12.05		39	15	19.70
40202D14-...-...	13.95		40	16	21.60
40202D16-...-...	15.75		41	18	23.40
40202D18-...-...	18.05		43	19	25.70
40202D20-...-...	19.93		44	21	27.58

UNLESS OTHERWISE SPECIFIED, DIMENSIONS ARE IN INCHES. TOLERANCES ARE: DECIMALS .005, ANGLES ± 0.5°, .XXX ± .01, INTERPRET PER ASME Y14.5M, BREAK EDGES - .015/.003, FILLET RADIUS - .020/.005, SURFACE ROUGHNESS - 125 RMS PER ANS1 842.1.

DO NOT SCALE DRAWING

CONTRACT		2236 Rutherford Road, Suite 119 Carlsbad, California 92008 California Linear Devices, Inc. www.callinear.com	
APPROVALS	DATE	TITLE	
C. GUFFEY	9/9/02	40202D HIGH RESPONSE MOTOR	
C. ELLARD	2/7/03	SIZE	CAGE CODE
G. SCHULTZE	2/7/03	SCALE	DWG NO.
P. HOLLINGSWORTH	2/7/03	1:2	ICD - 40202D
QUALITY ASSURANCE		MODEL FILE NAME	REV.
		40202D rev A	A
		SHEET	1 OF 2

THIS DOCUMENT CONTAINS PROPRIETARY INFORMATION, AND EXCEPT WITH WRITTEN PERMISSION OF CALIFORNIA LINEAR DEVICES, INC. SUCH INFORMATION SHALL NOT BE PUBLISHED OR DISCLOSED TO OTHERS, OR USED FOR ANY PURPOSE, AND THE DOCUMENT SHALL NOT BE DUPLICATED IN WHOLE OR IN PART.

REVISION HISTORY			
REV.	DESCRIPTION	DATE	APPROVED
	SEE SHEET - 1 FOR REVISIONS		

