

THIS DOCUMENT CONTAINS PROPRIETARY INFORMATION, AND EXCEPT WITH WRITTEN PERMISSION OF CALIFORNIA LINEAR DEVICES, INC. SUCH INFORMATION SHALL NOT BE PUBLISHED OR DISCLOSED TO OTHERS, OR USED FOR ANY PURPOSE, AND THE DOCUMENT SHALL NOT BE DUPLICATED IN WHOLE OR IN PART.

DWG NO. ICD - 40206D SH 1 REV. A

REVISION HISTORY			
REV.	DESCRIPTION	DATE	APPROVED
A	INITIAL RELEASE PER ECO #0109	2/7/03	PH

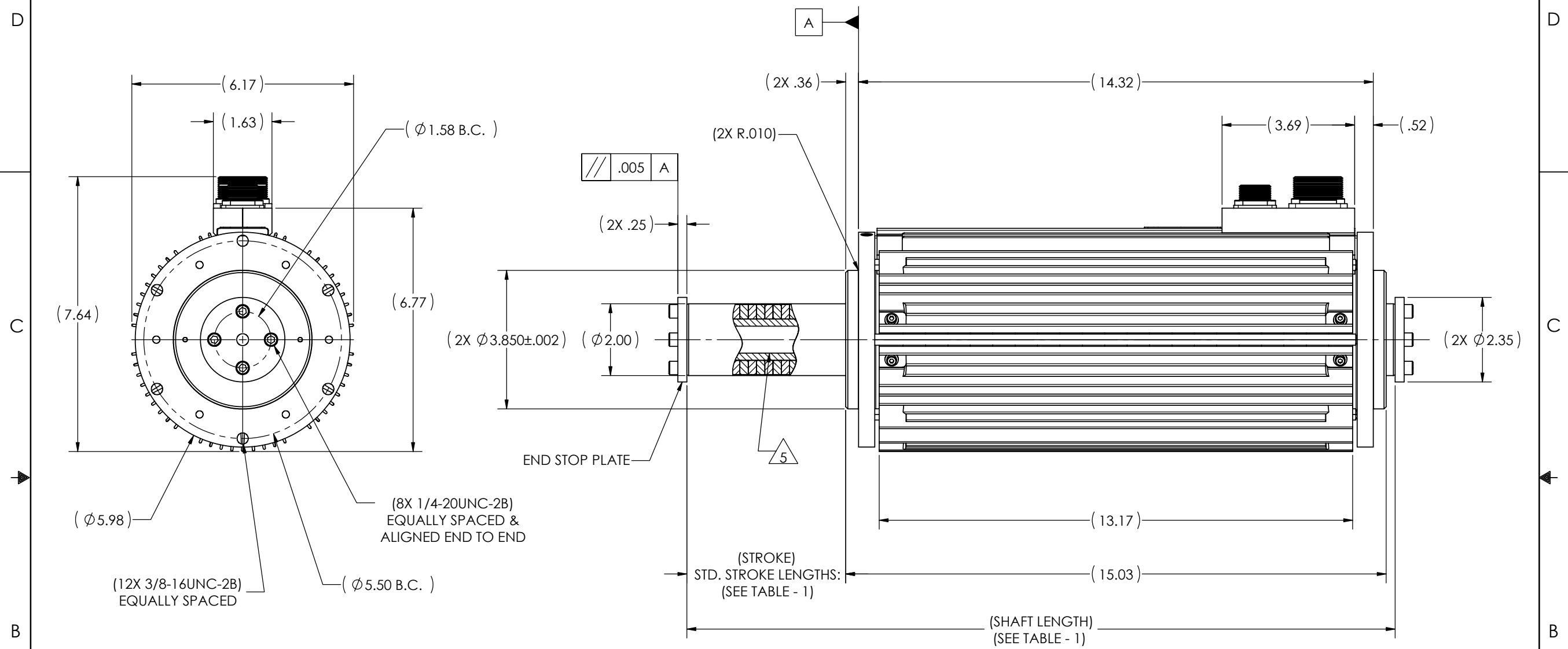

INTERFACE CONTROL DRAWING

- 5. MOTOR SHAFT CONTAINS A .75 STANDARD TUBING INNER DIAMETER.
- 4. FOR INFORMATION NOT CONTAINED ON THIS DRAWING, REFER TO USERS MANUAL (REF. UM-102).
- 3. MODEL SHOWN: 40206D...-...-CV.
- 2. THE MOTOR BEARINGS ARE NOT INTENDED TO SUPPORT RADIAL LOADS. THIS WILL RESULT IN ACCELERATED BEARING WEAR. PLEASE CONSULT CLD REGARDING YOUR APPLICATION IF RADIAL LOADS ARE EXPECTED.
- 1. CAUTION: DO NOT OPERATE THE MOTOR WITHOUT THE END STOP PLATES OR AN EXTERNAL STOP TO CONTAIN THE SHAFT IN THE STATOR.

NOTES: UNLESS OTHERWISE SPECIFIED

MODEL NO.	STROKE LENGTH IN INCHES (NOMINAL)	POLE PITCH IN INCHES	ESTIMATED MOTOR WEIGHT IN LBS.	ESTIMATED SHAFT WEIGHT IN LBS.	SHAFT LENGTH IN INCHES
40206D02.-...-...	2.82	.922	60	13	17.85
40206D04.-...-...	4.67		61	15	19.70
40206D06.-...-...	6.57		62	16	21.60
40206D08.-...-...	8.37		63	18	23.40
40206D10.-...-...	10.67		65	19	25.70
40206D12.-...-...	12.55		66	21	27.58

<small>UNLESS OTHERWISE SPECIFIED, DIMENSIONS ARE IN INCHES. TOLERANCES ARE: DECIMALS .005 ANGLES ± 0.5° .XXX ± .01 INTERPRET PER ASME Y14.5M BREAK EDGES - .015/.003 FILLET RADIUS - .020/.005 SURFACE ROUGHNESS 125 RMS PER ANSI B46.1</small> DO NOT SCALE DRAWING	CONTRACT		2236 Rutherford Road, Suite 119 Carlsbad, California 92008 California Linear Devices, Inc. www.callinear.com	
	APPROVALS	DATE		
	DRAWN	C. GUFFEY	9/11/02	40206D HIGH RESPONSE MOTOR
	CHECKED MECHANICAL	C. ELLARD	2/7/03	
CHECKED ELECTRICAL	G. SCHULTZE	2/7/03	SCALE: C CAGE CODE: _____ DWG NO.: ICD - 40206D REV.: A	
CHECKED QUALITY ASSURANCE	P. HOLLINGSWORTH	2/7/03	MODEL FILE NAME: 40206D rev. A SHEET 1 OF 2	

THIS DOCUMENT CONTAINS PROPRIETARY INFORMATION, AND EXCEPT WITH WRITTEN PERMISSION OF CALIFORNIA LINEAR DEVICES, INC. SUCH INFORMATION SHALL NOT BE PUBLISHED OR DISCLOSED TO OTHERS, OR USED FOR ANY PURPOSE, AND THE DOCUMENT SHALL NOT BE DUPLICATED IN WHOLE OR IN PART.

REVISION HISTORY			
REV.	DESCRIPTION	DATE	APPROVED
	SEE SHEET - 1 FOR REVISIONS		

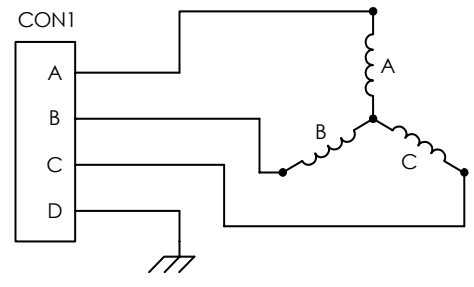

POWER CONNECTOR PINOUT

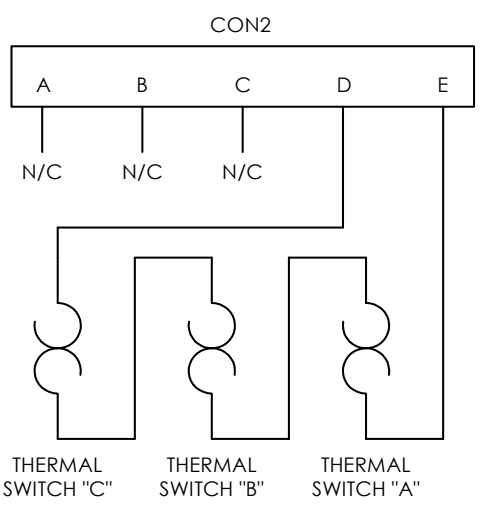
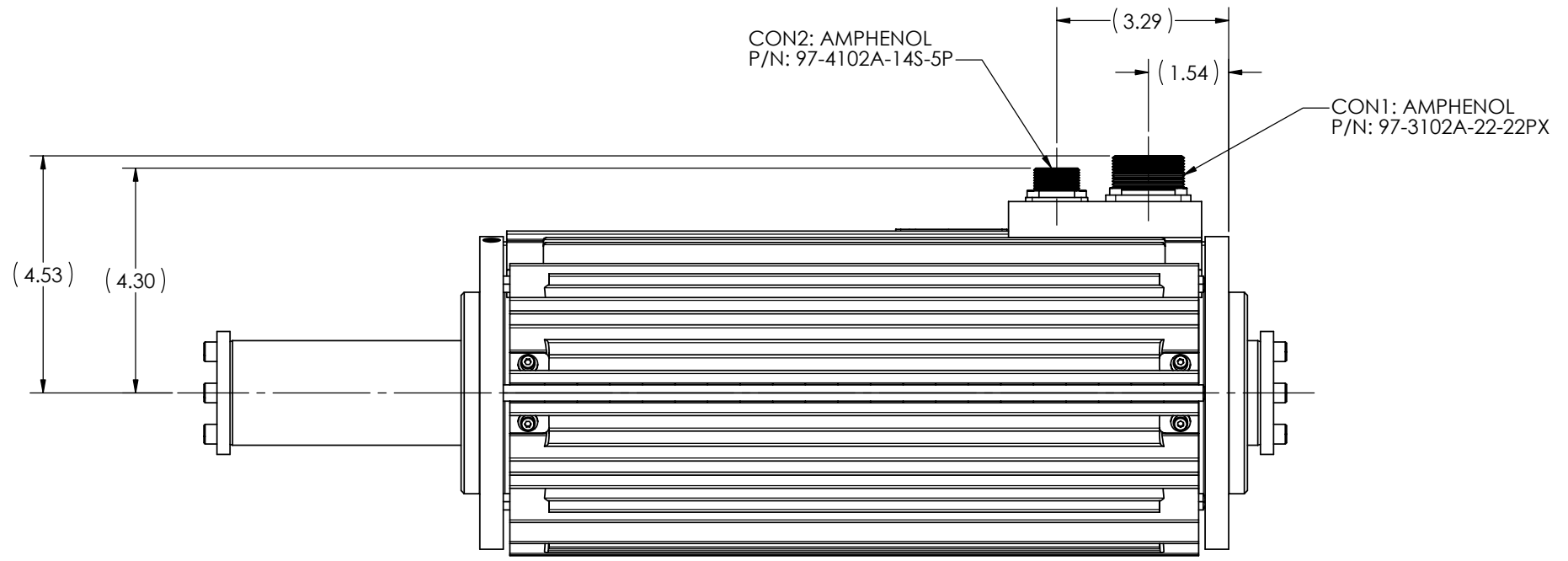

TEMPERATURE CONNECTOR PINOUT (OPTION - T)

DRAWN	C. GUFFEY	DATE	9/11/02	 California Linear Devices, Inc. 2236 Rutherford Road, Suite 119 Carlsbad, California 92008 www.callinear.com			
SCALE	1:2	MODEL FILE NAME	40206D rev A				
SIZE	C	CAGE CODE		DWG NO.	ICD - 40206D	REV.	A
SHEET			2	OF		2	