

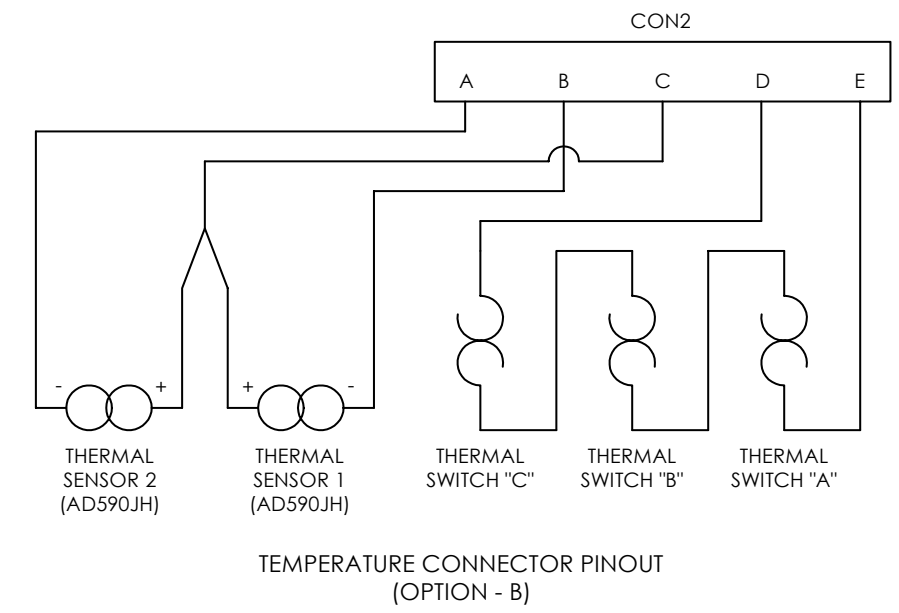

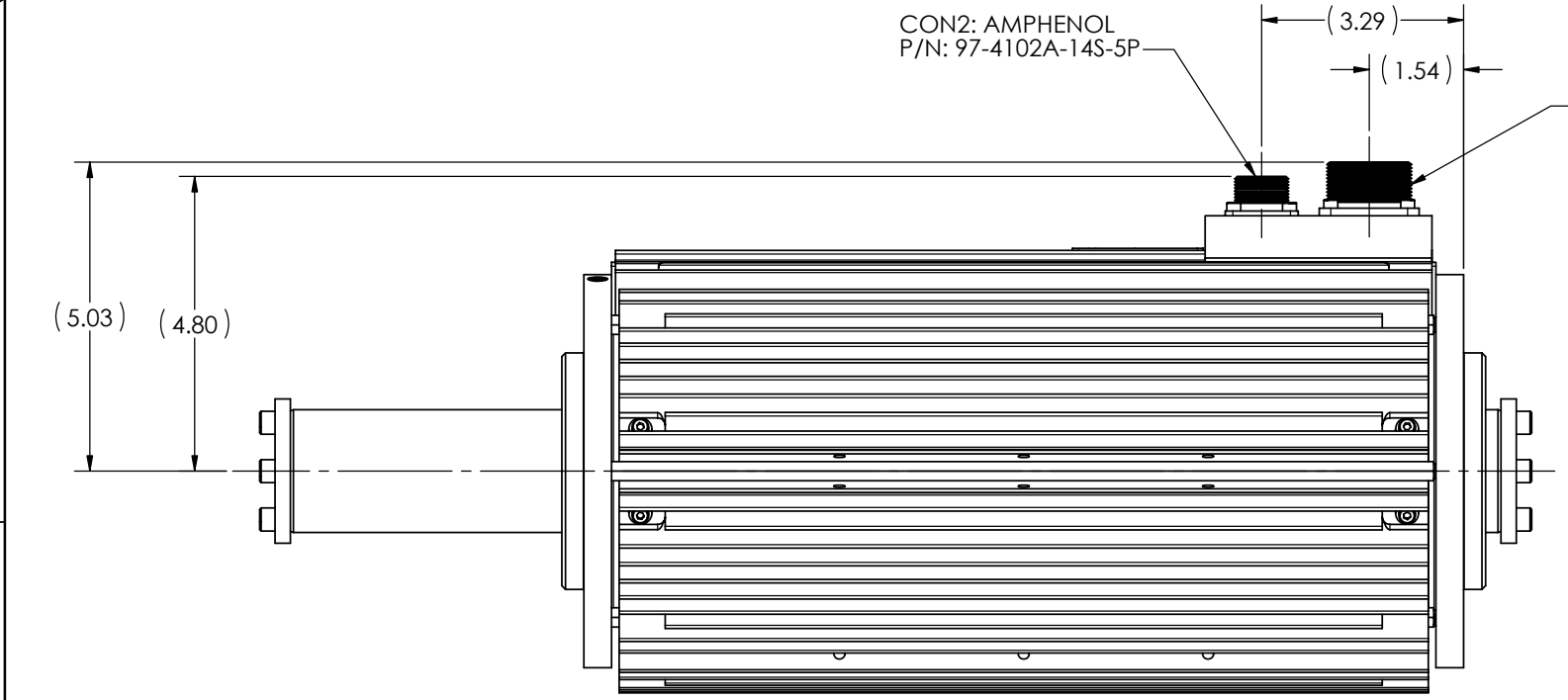
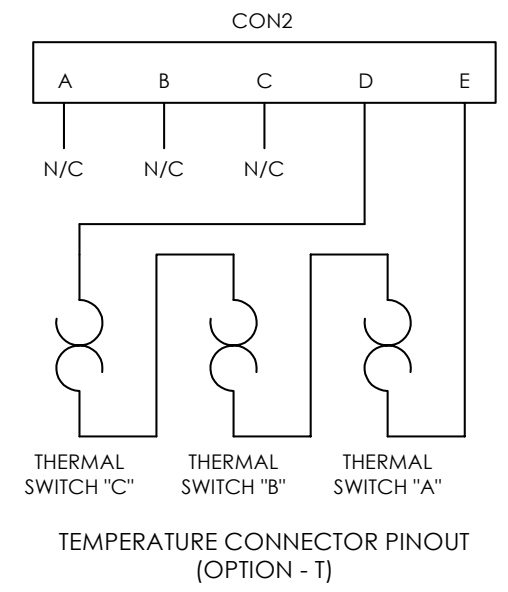
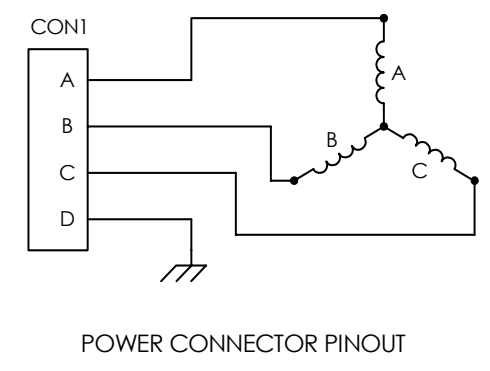
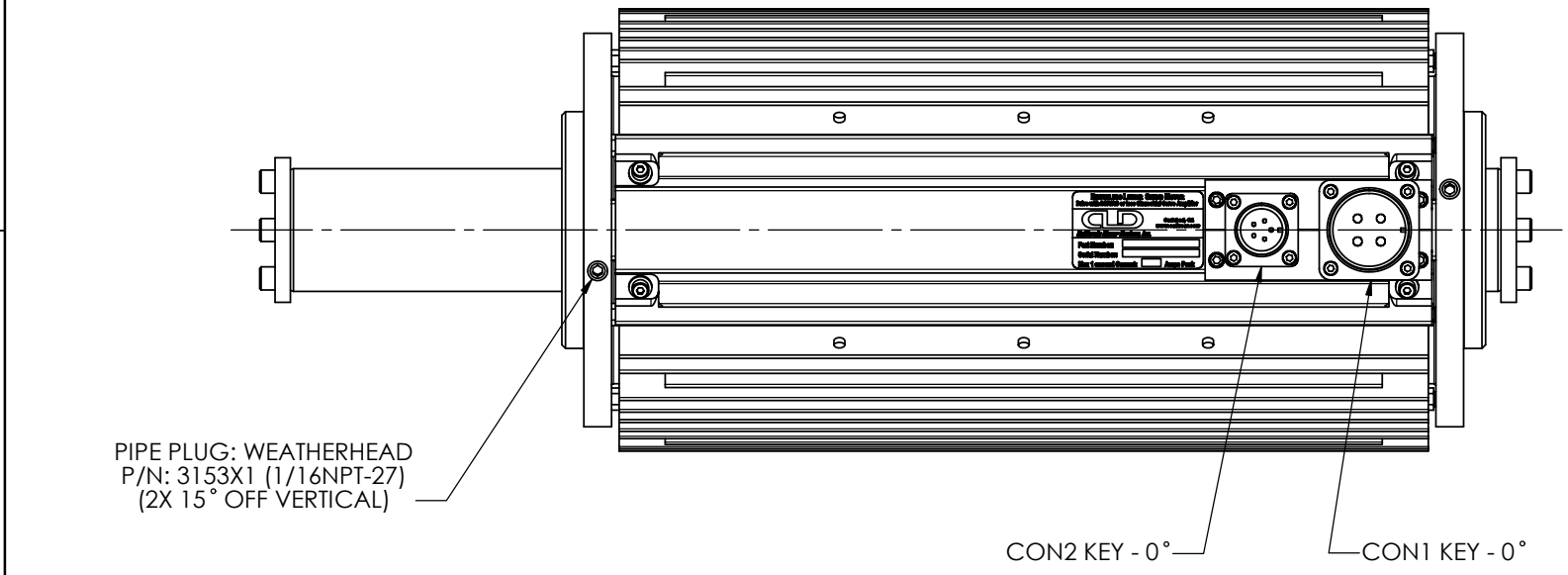

THIS DOCUMENT CONTAINS PROPRIETARY INFORMATION, AND EXCEPT WITH WRITTEN PERMISSION OF CALIFORNIA LINEAR DEVICES, INC., SUCH INFORMATION SHALL NOT BE PUBLISHED OR DISCLOSED TO OTHERS, OR USED FOR ANY PURPOSE, AND THE DOCUMENT SHALL NOT BE DUPLICATED IN WHOLE OR IN PART.

DWG NO. ICD - 50206C SH 2 REV. A

REVISION HISTORY			
REV.	DESCRIPTION	DATE	APPROVED
	SEE SHEET - 1 FOR REVISIONS		



DRAWN C. GUFFEY	DATE 9/11/02	 <b>California Linear Devices, Inc.</b> 2236 Rutherford Road, Suite 119 Carlsbad, California 92008 www.callinear.com	DWG NO. <b>ICD - 50206C</b>	REV. <b>A</b>
SCALE 1:2	MODEL FILE NAME 50206C rev A		SHEET 2 OF 2	